

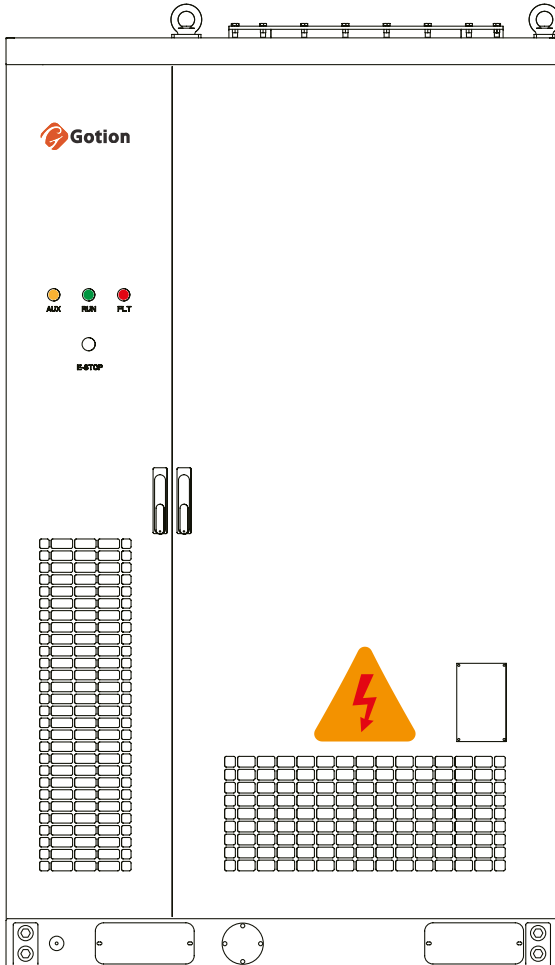

Integrated Commercial and Industrial Energy Storage Cabinet

Quick Installation Manual



Before installing the equipment, please read the user manual thoroughly to understand product information and safety precautions. Damage resulting from failure to store, transport, install, or use the equipment in compliance with this document and the user manual will not be covered under the product warranty.

This document may be updated periodically due to product version upgrades or other reasons. Unless otherwise agreed, this document is intended for guidance purposes only. All statements, information, and recommendations provided herein do not constitute any express or implied warranty.

Contents

Appendix 01	1
1.Product Appearance	2
1.1 Dimensions	2
1.2 Functional Area	3
2.ESS Installation	4
2.1 Packaging Removal	4
2.2 Cabinet Handling	5
2.3 Maintenance Channel	7
2.4 Anchor ixing	8
2.5 Install Blocking Plate	9
Appendix 02	10
2.6 Outlet method	11
3.Wiring	14
3.1 Ground Wire	14
3.2 Power Line	16
3.3 Communication Line	18
3.4 Follow-up Procedure	20
4. Check Before Power-On	21
5.Power-On	23
5.1 Connecting battery pack cables	24
5.2 AC side power-on process	25

◆ Appendix 01

• Protective Gear

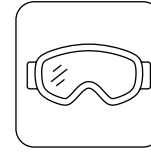

Goggles

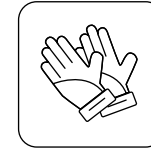

Insulated gloves

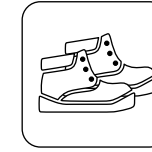

safety shoes

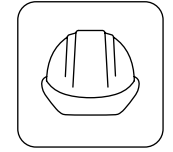

helmet

• Installation Tools

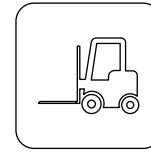

forklift

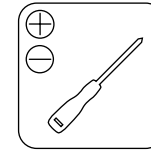

screwdriver set

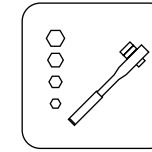

socket wrench set

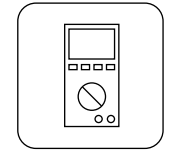

multimeter

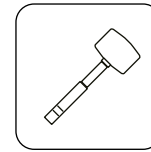

hammer

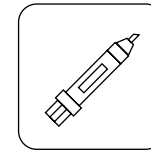

marker

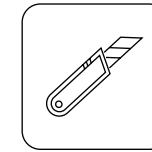

utility knife

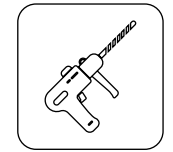

impact drill

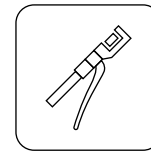

Crimping pliers

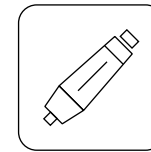

heat gun

• Installing Supplies

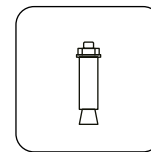

Expansion bolt

diameter M12 or 1/2''
(length depends on the site, recommended ≥80mm)

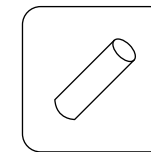

heat shrink tubing

1. Product Appearance

1.1 Dimensions

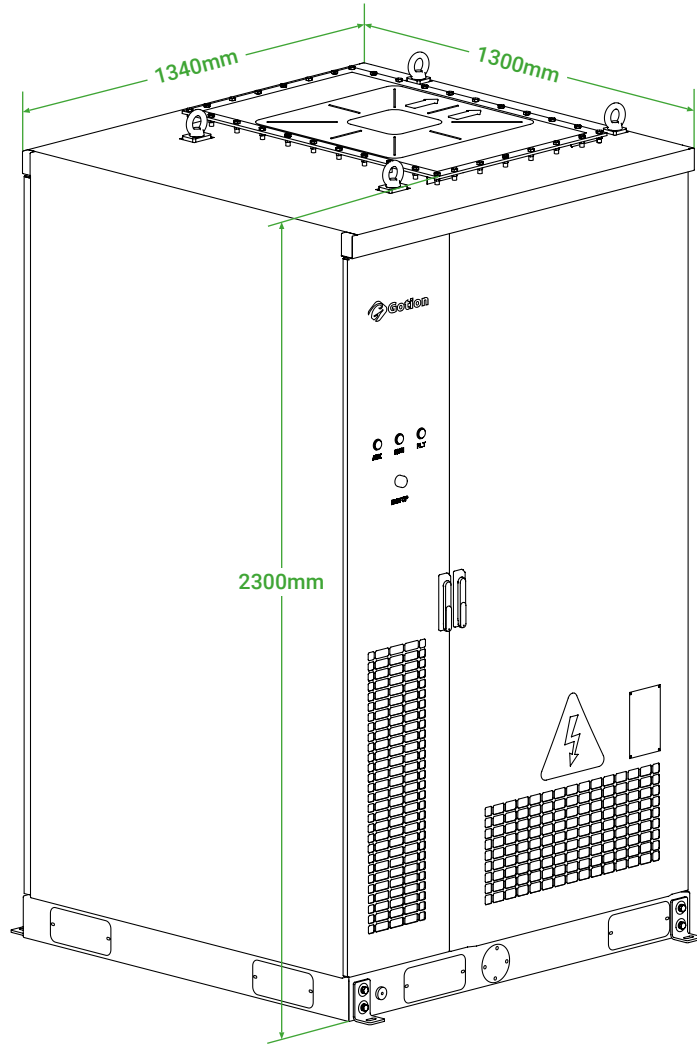

1.2 Functional Area

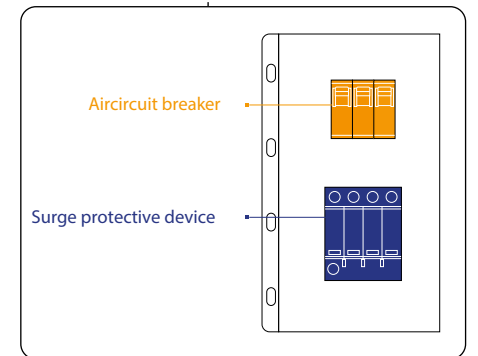
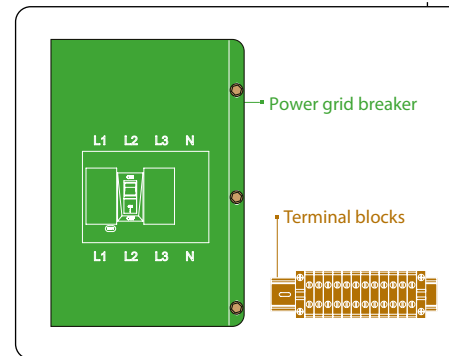
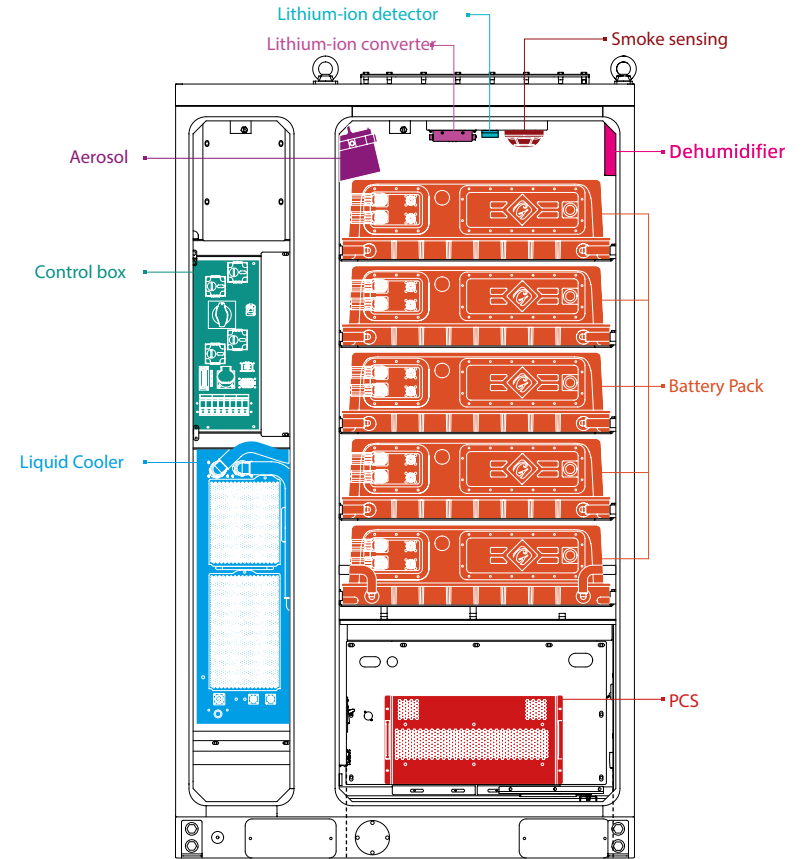

2.ESS Installation

2.1 Packaging Removal

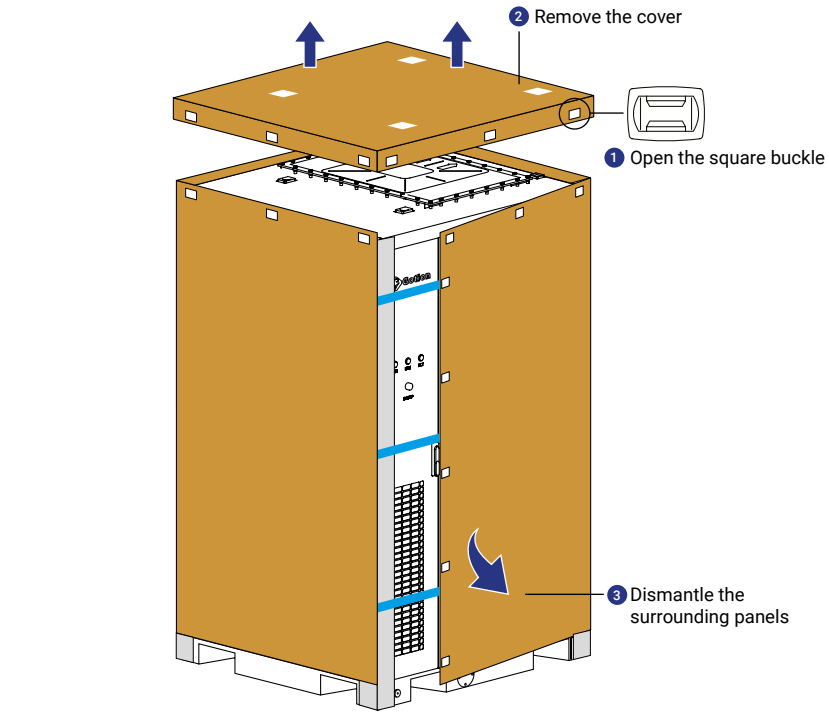

4 Cut the tie

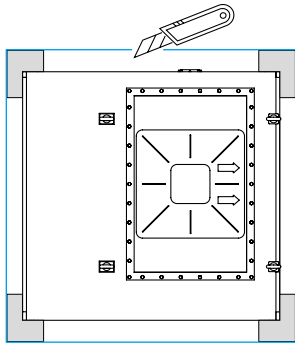

5 Remove the EPE cushioning cotton

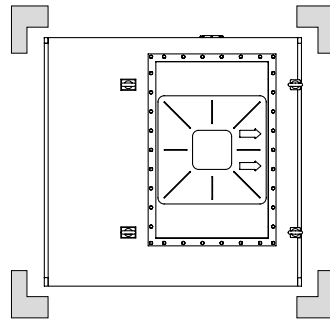

2.2 Cabinet Handling

Plan A : Forklift handling

• Forklift: load-bearing capacity $\geq 3t$

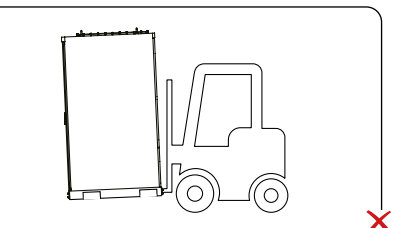
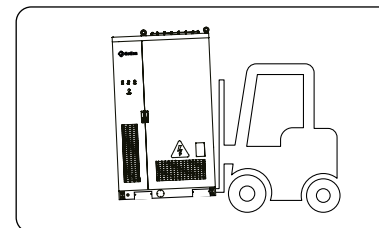
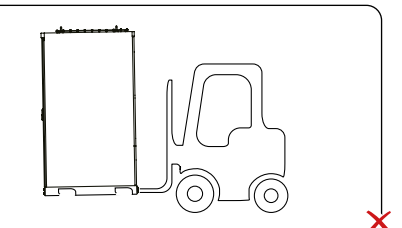
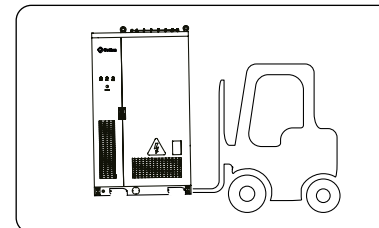
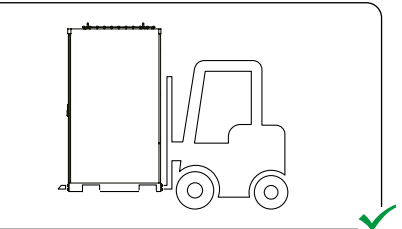
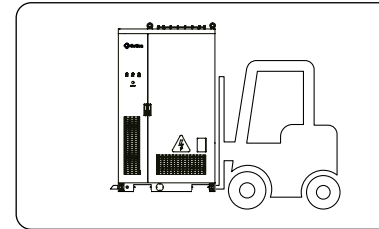
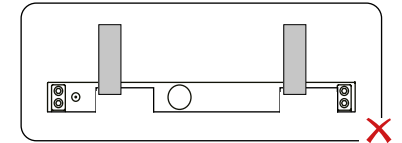
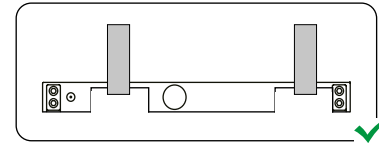
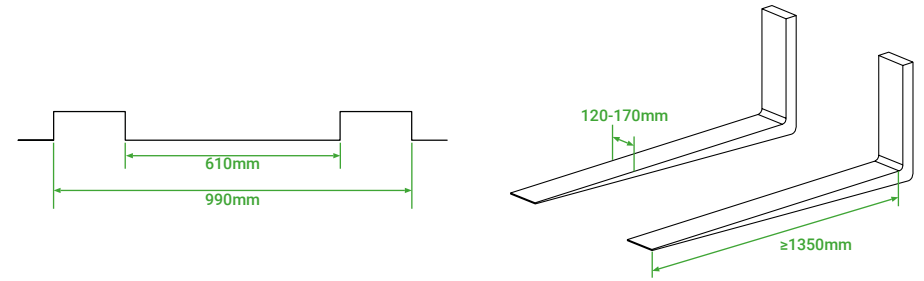

2.2 Cabinet Handling

Plan B : Crane handling

- hoisting capacity $\geq 3t$ operating radius $\geq 2m$

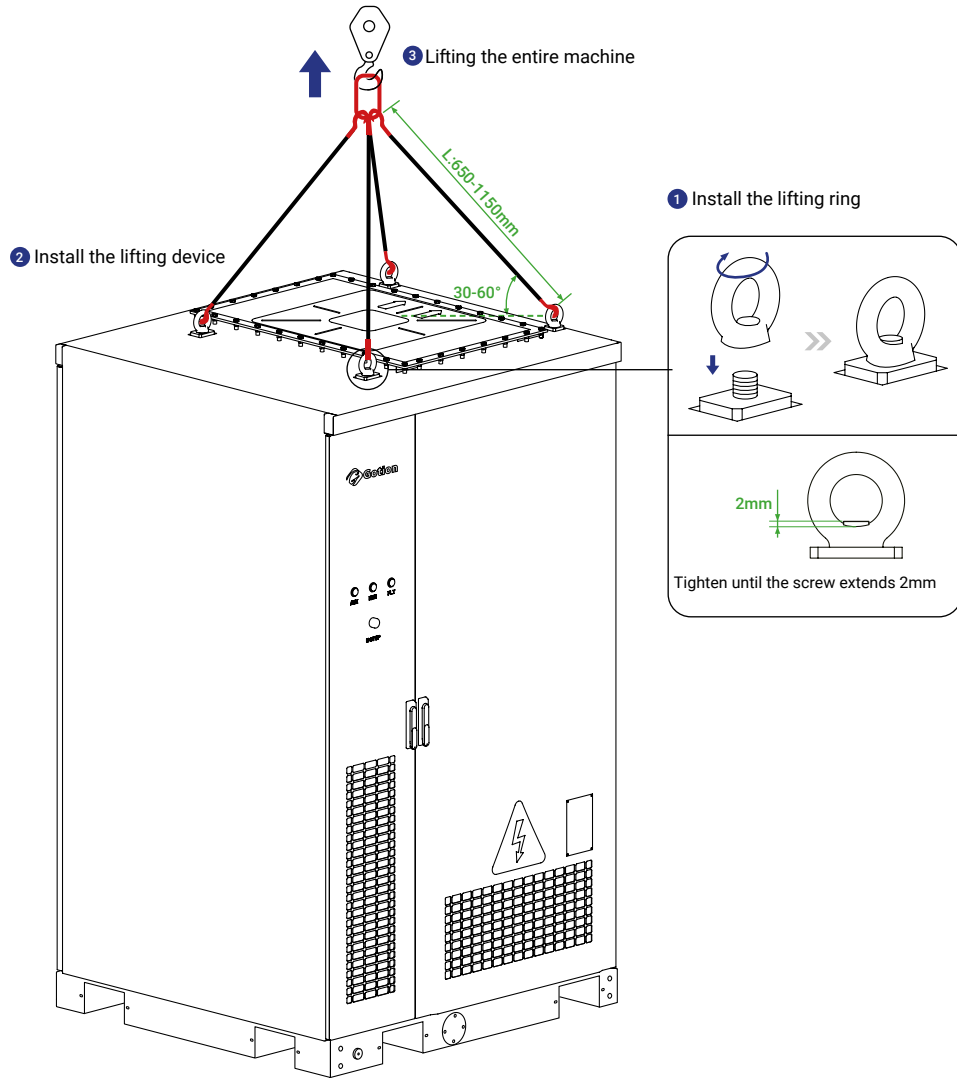

2.3 Maintenance Channel

A. Back to Back

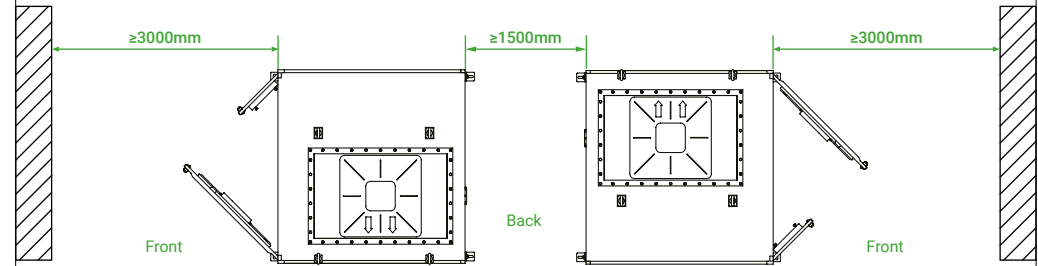

B. Face to Face

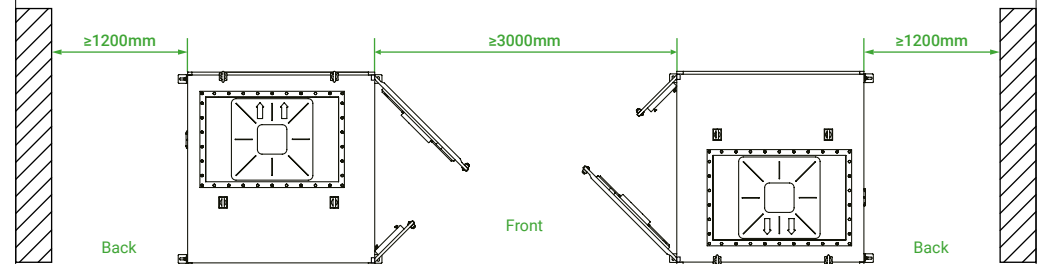

C. Parallel operation

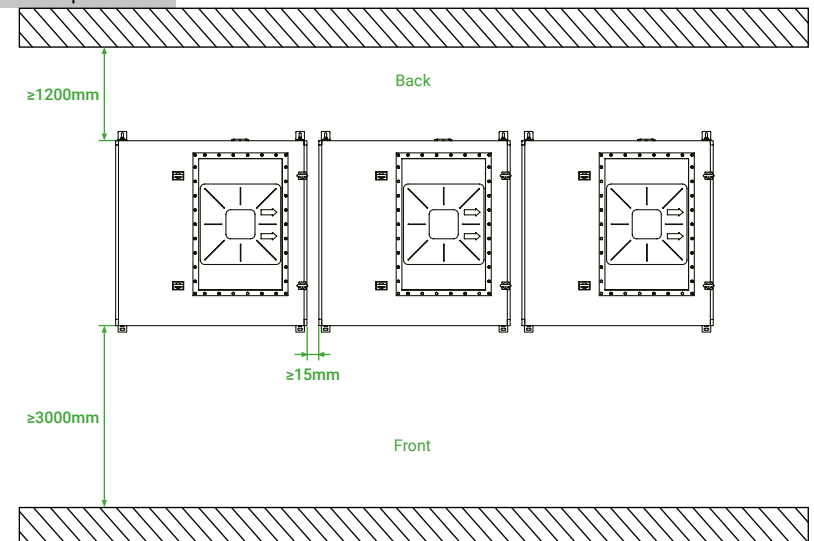

2.4 Anchor fixing

2.4.1 Equipment fixation

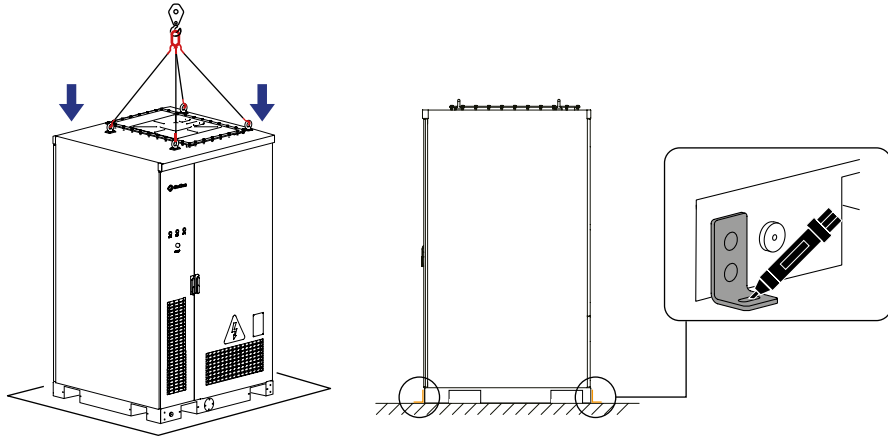

2.4.2 Install expansion screws

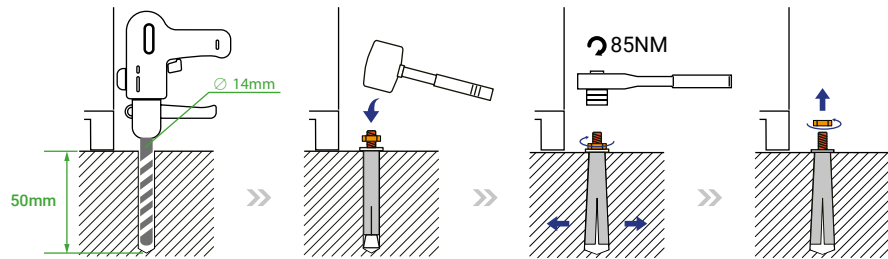

2.4.3 Install cabinet fixings

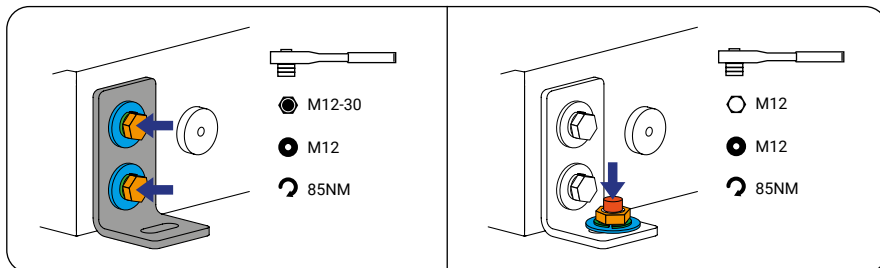

2.5 Install Blocking Plate

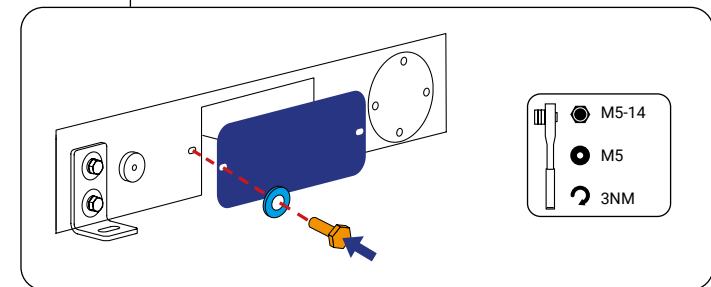
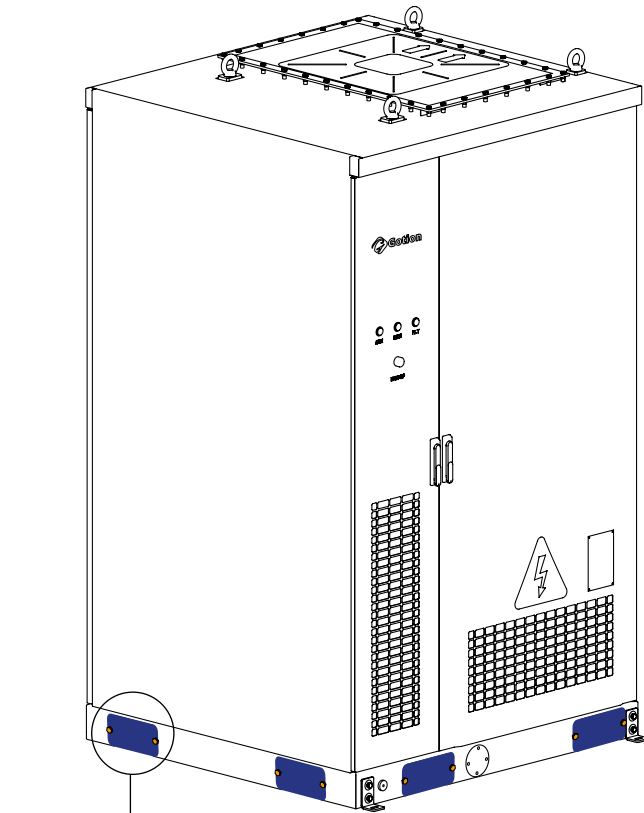

◆ Appendix 02

Bottom outlet hole parameters

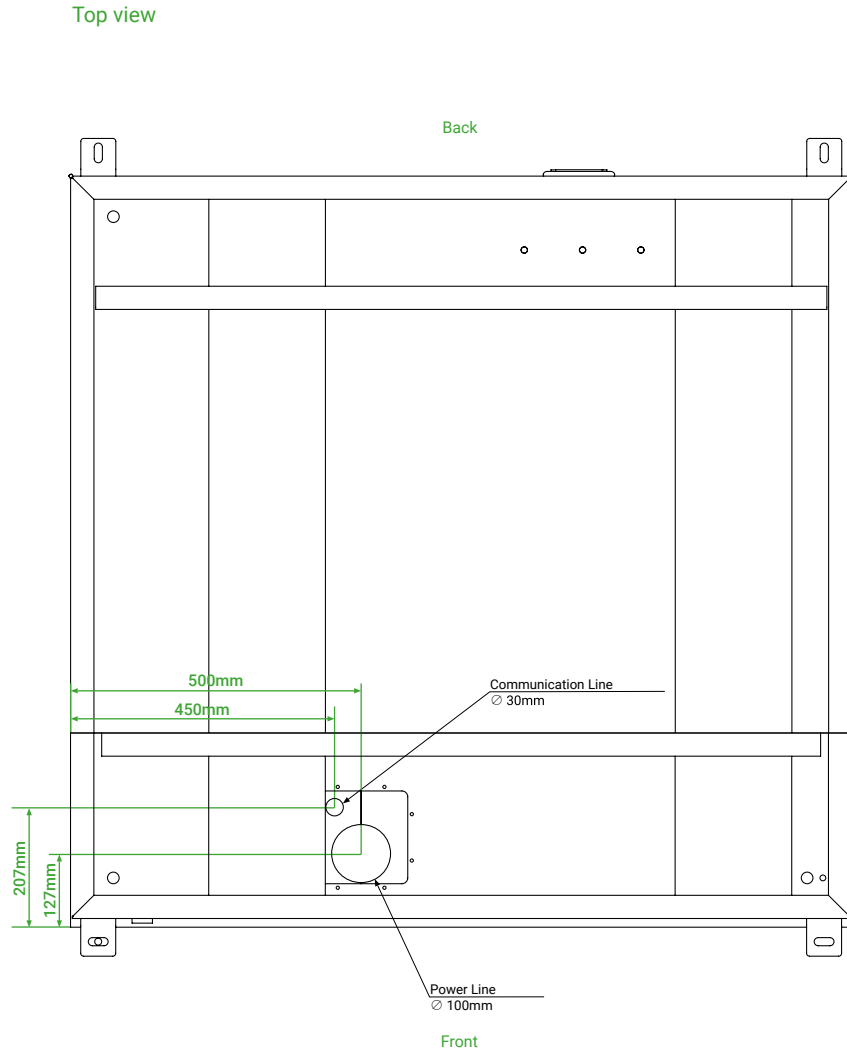

2.6 Outlet method

Three outlet schemes are provided

Scheme 1: Bottom outlet

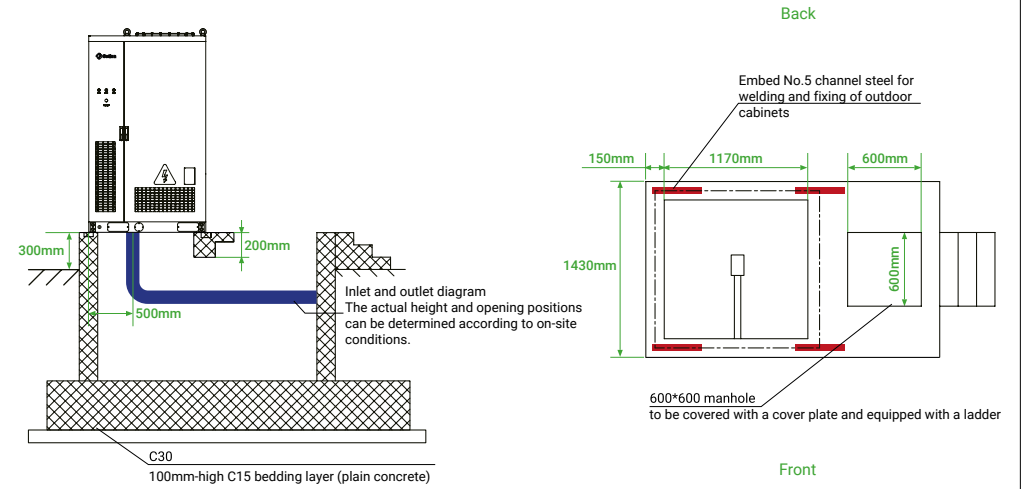

Parallel operation

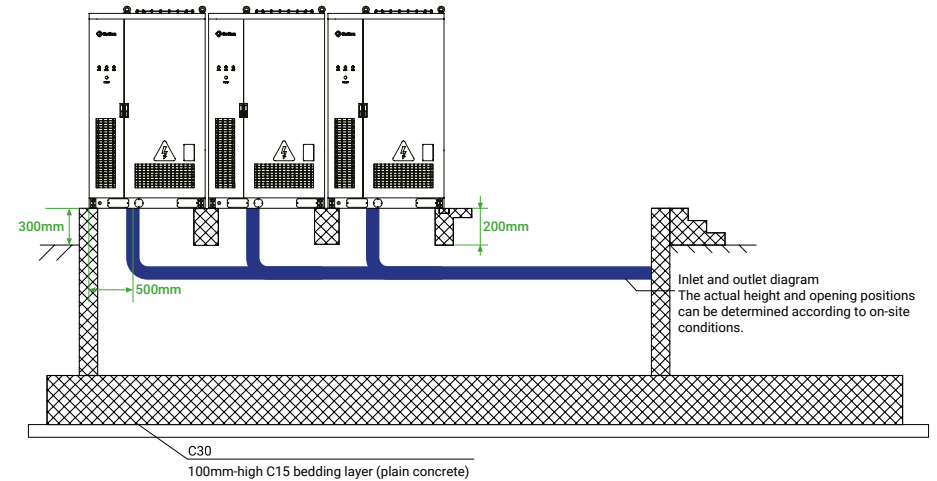

Scheme 2: Bracket side outlet

• Please contact salesperson for Bracket's drawings

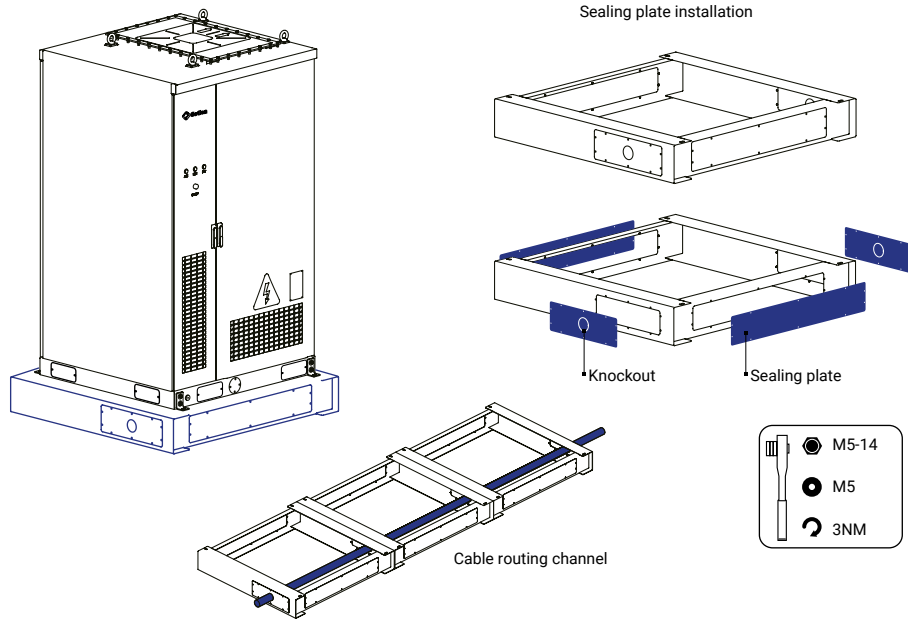

Parallel operation

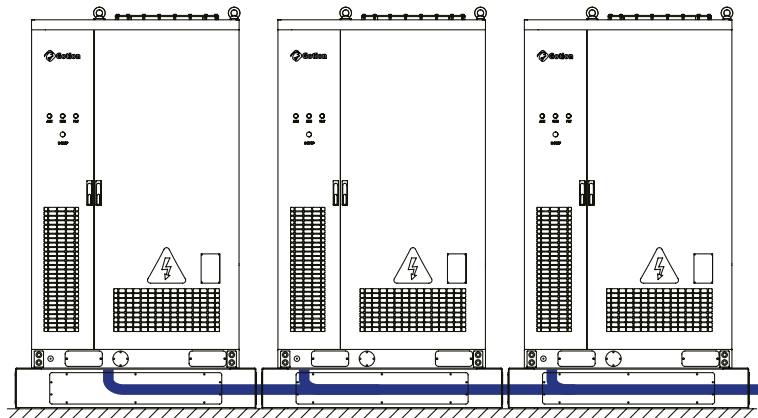

Scheme 3: Front-end outlet

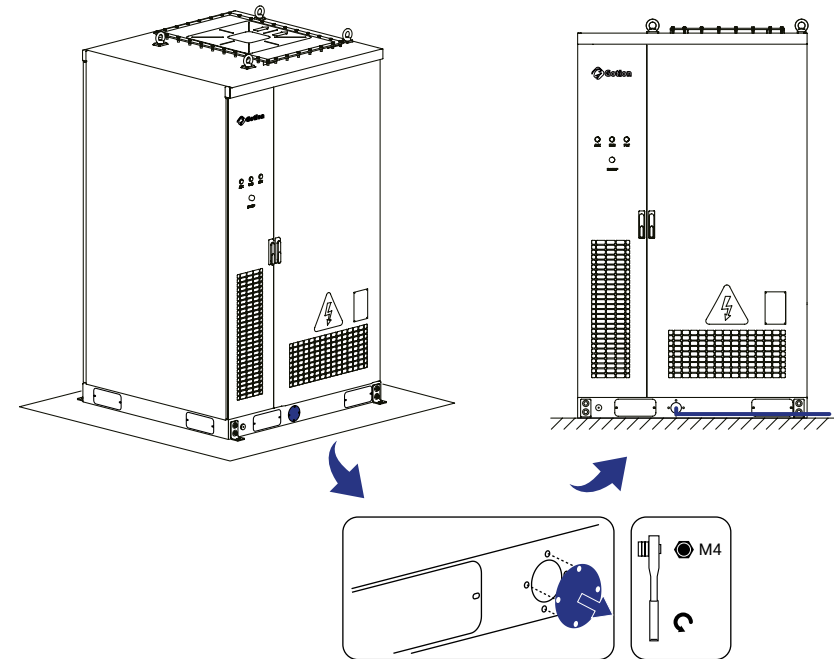

Parallel operation

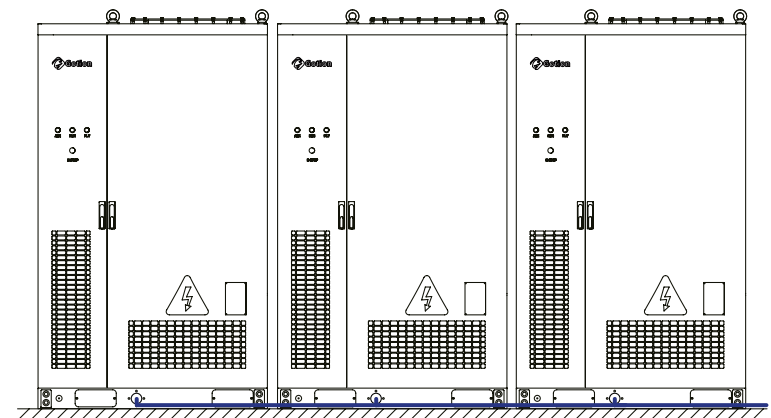

3. Wiring

3.1 Ground Wire

•Single-core outdoor copper/copper-clad aluminum/aluminum alloy cable

Plan A:

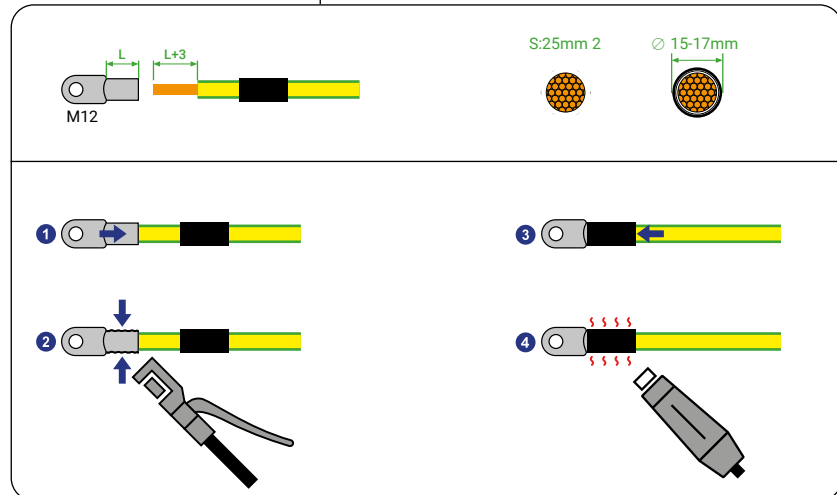
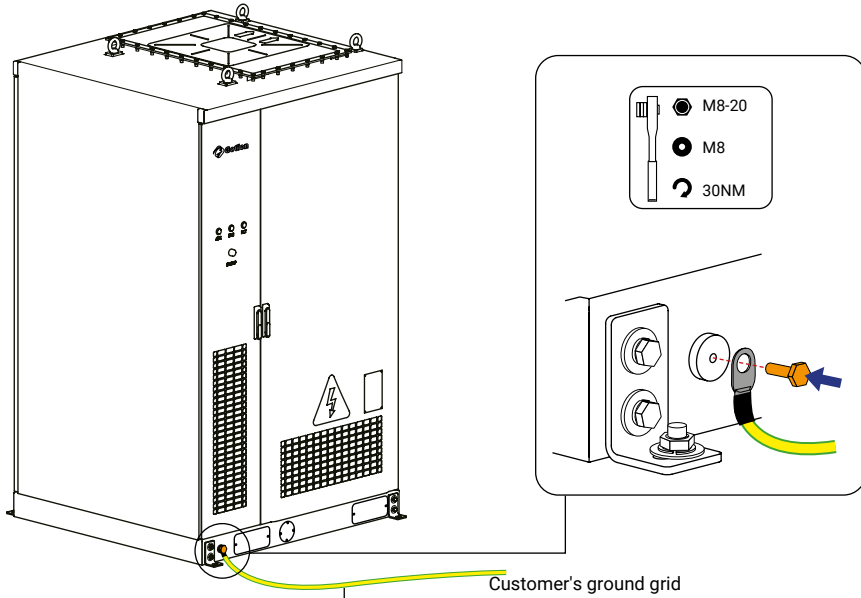

3.1 Ground Wire

Plan B:

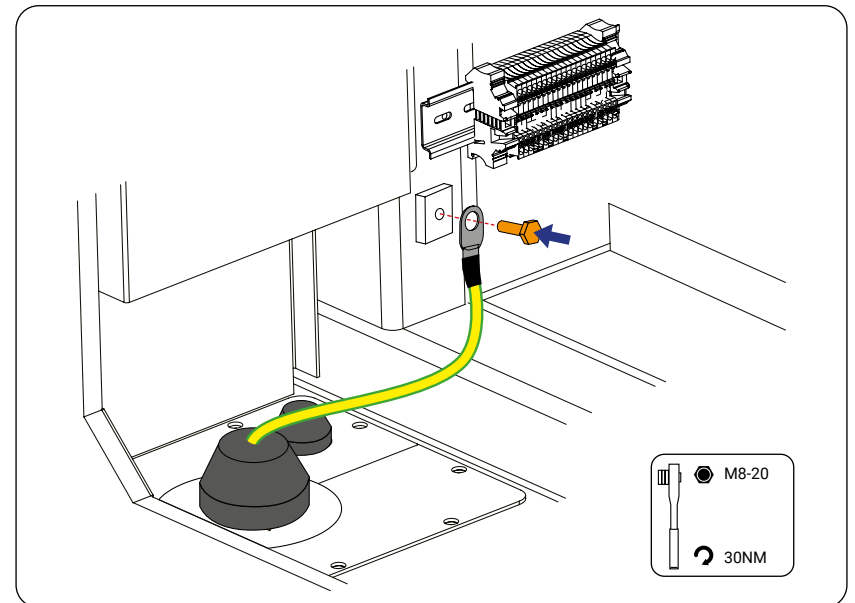
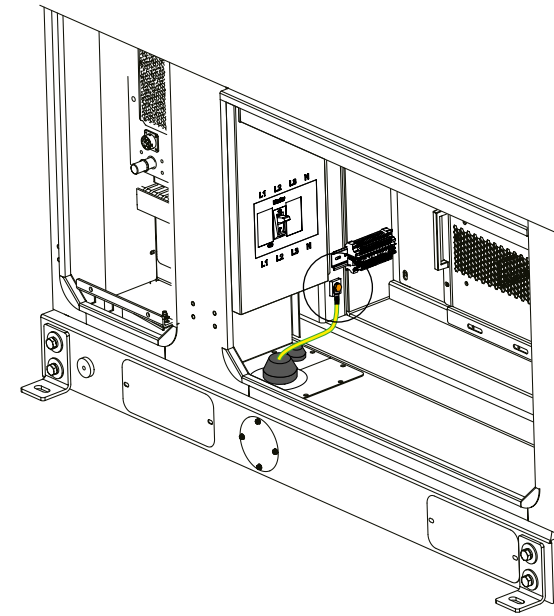

3.2 Power Line

•The selection of wire diameter should comply with local cable standards

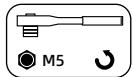
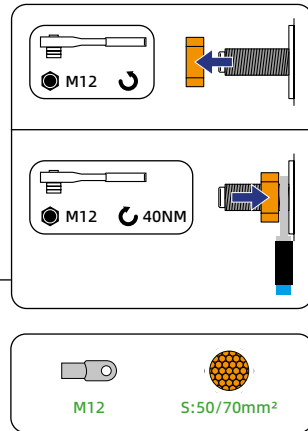
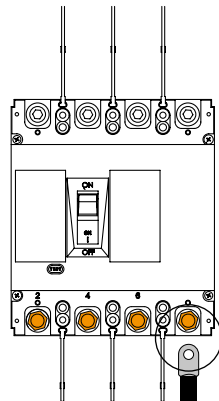
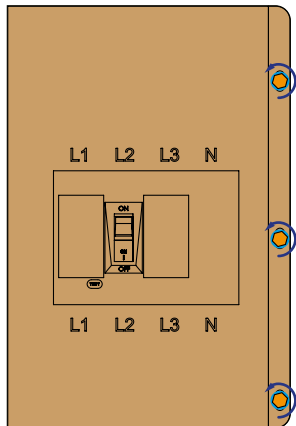
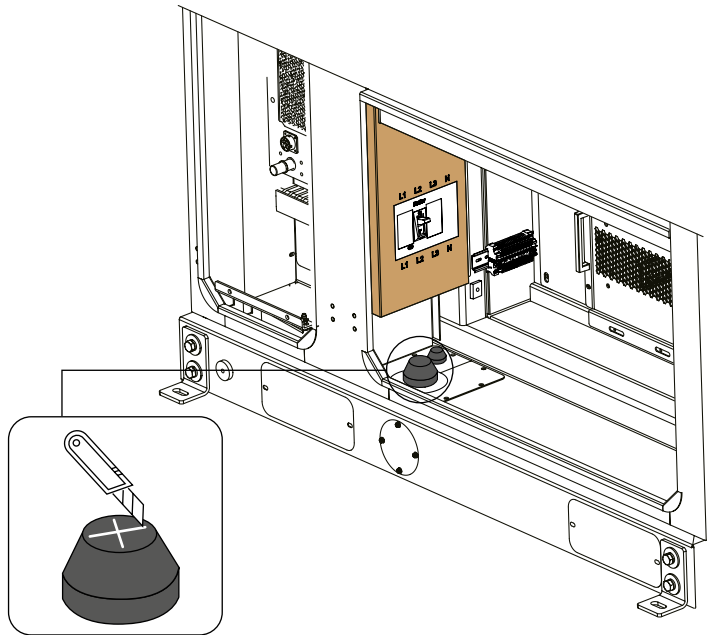

3.2 Power Line

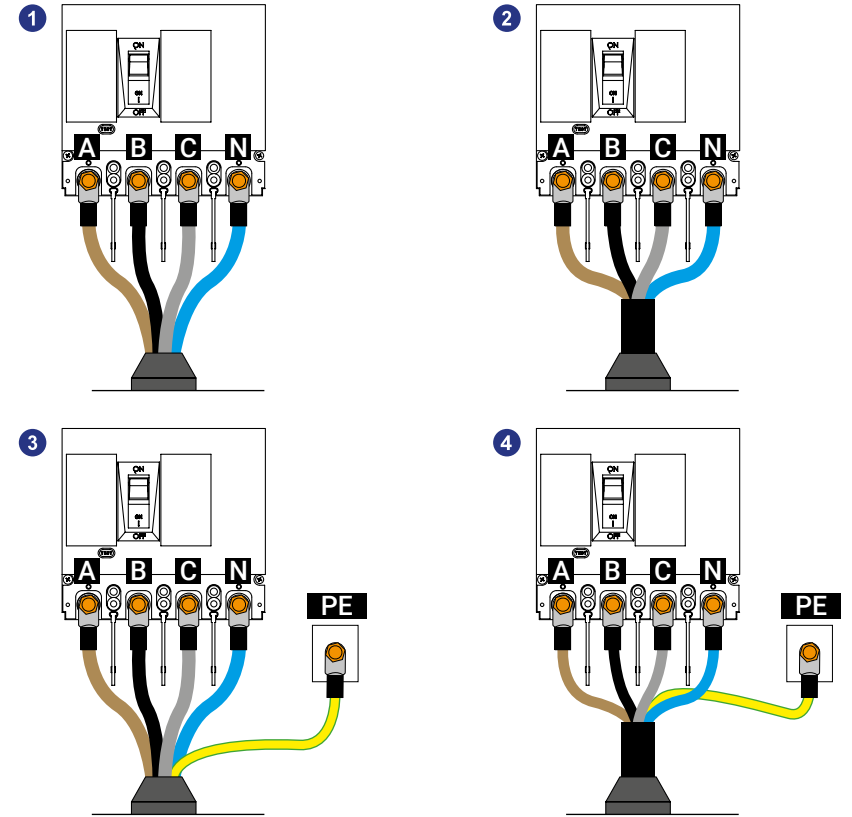

fix the cover after completing the wiring

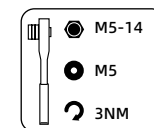
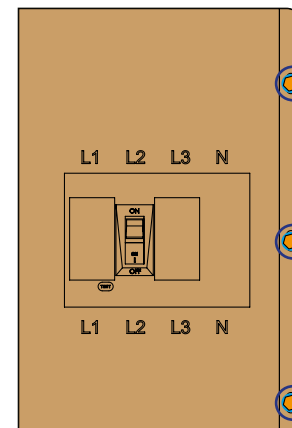

3.3 Communication Line

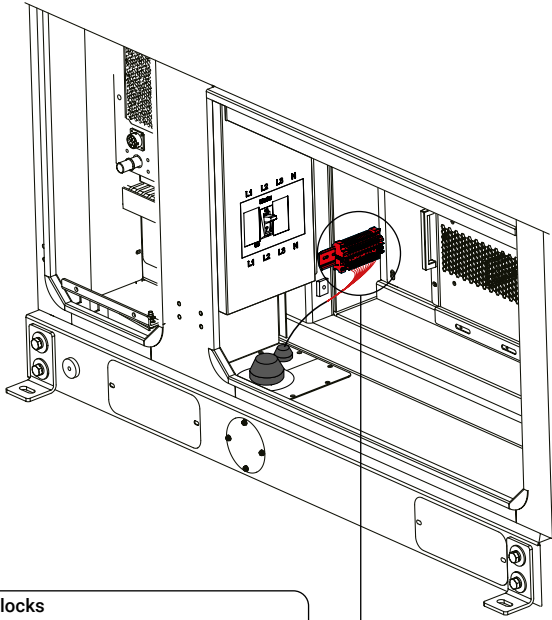

Terminal blocks



Number	Manager	Wire Gauge	Description
1	24V+	2*0.5mm ²	24V, ≤ 20W power output (only for equipment inside the cabinet)
2	0V		
3	485B1	2*0.35mm ² (Shielded twisted pair)	Parallel operation or communication with external EMS (Modbus-RTU protocol, baud rate 9600)
4	485A1		
5	232 R2	3*0.35mm ²	Used to connect to the Ethernet module and communicate using the MQTT protocol (the 232-to-Ethernet module is not included by default and can be configured as an optional accessory)
6	232 T2		
7	232 GND2		
8	GL+	0.5mm ²	12V, ≤ 10W isolated power output (for equipment inside the cabinet only)
9	GL-		
10	485A3	2*0.35mm ² (Shielded twisted pair)	PCS off-grid parallel communication
11	485B3		

3.3 Communication Line

Modbus-TCP

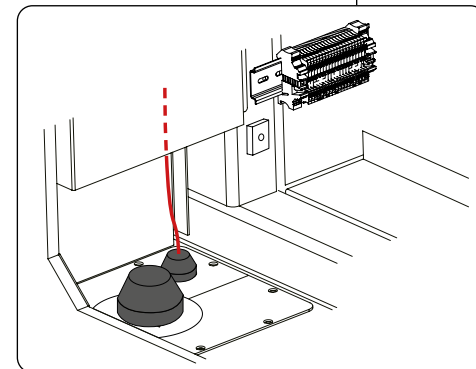
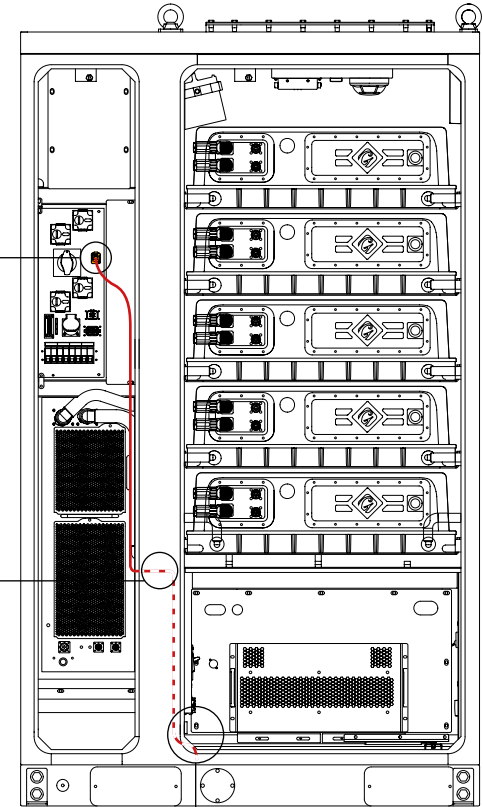
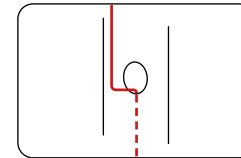
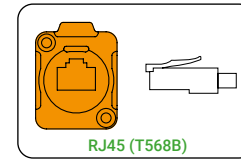

3.4 Follow-up Procedure

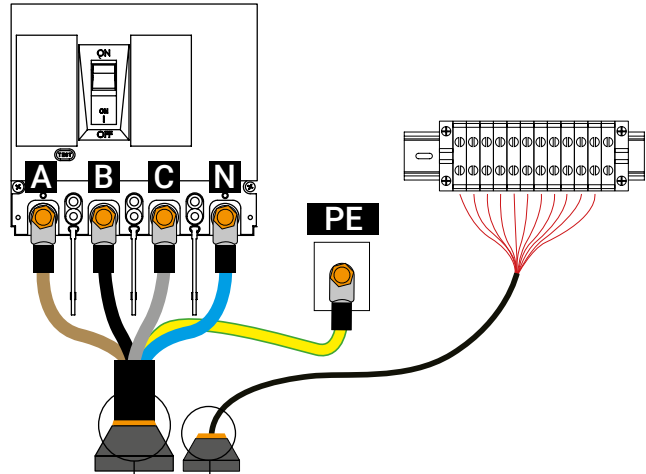

4. Check Before Power-On

Equipment exterior	<input type="checkbox"/> The device is in good condition, free of damage, dents, rust, or paint peeling. <input type="checkbox"/> The device label is clearly visible, undamaged, warped, or faded. <input type="checkbox"/> The nameplate is intact and legible. <input type="checkbox"/> The battery pack label is clear and accurate.
Equipment components	<input type="checkbox"/> The hatch should open and close normally. <input type="checkbox"/> The door lock should open and close normally. <input type="checkbox"/> The firefighting equipment should be externally undamaged. <input type="checkbox"/> The aerosol housing should be securely fixed and not loose. <input type="checkbox"/> The aerosol head detonator should be securely installed. <input type="checkbox"/> The detector should be securely installed (the hand-ranked detector should not shake), and the wire connections should be secure. <input type="checkbox"/> The PCS, liquid cooler and piping, firefighting equipment, control box, battery pack, and other components should be correctly installed.
Maintenance channel	<input type="checkbox"/> When using a cabinet structure with multiple rows, the cabinet layout maintenance channel width should meet the requirements of this manual.
Switch	<input type="checkbox"/> The switch is in the off position
Cable	Cable exterior <input type="checkbox"/> The cable is clearly colored and marked, the insulation is intact. <input type="checkbox"/> The cable duct is functioning properly. <input type="checkbox"/> The cable retaining ring is intact and in working order.
	Cable connection <input type="checkbox"/> Cable connections comply with the requirements of this manual. <input type="checkbox"/> Terminal connections are secure and meet specifications. <input type="checkbox"/> Labels are clearly labeled at both ends, with labels facing the same direction.
	Cable routing <input type="checkbox"/> Cables are neatly arranged, with no crossover. <input type="checkbox"/> Cable routing adheres to the principle of separating strong and weak currents. <input type="checkbox"/> Corners are properly sized with adequate margins and no cables are strained.
	Cable Material <input type="checkbox"/> The cable is flame retardant

5. Power-On



1. Wear insulated gloves and use insulated tools to prevent electric shock or short circuits.
2. During the power-on procedure, monitor the system for faults. If you detect any faults, power off the ESS, rectify the faults, and then continue with the procedure.
3. If batteries are fully discharged or overdischarged during system installation and commissioning, charge the batteries promptly to prevent damage due to overdischarge.
4. Storing batteries with low SOC may cause damage due to overdischarge. Charge the batteries promptly to prevent damage.
5. If the ESS has not been used for six months or longer after being installed, it must be checked and tested by professionals before operation.

5.1 Connecting battery pack cables

The battery pack power supply series line is disconnected when shipped and needs to be connected by the customer

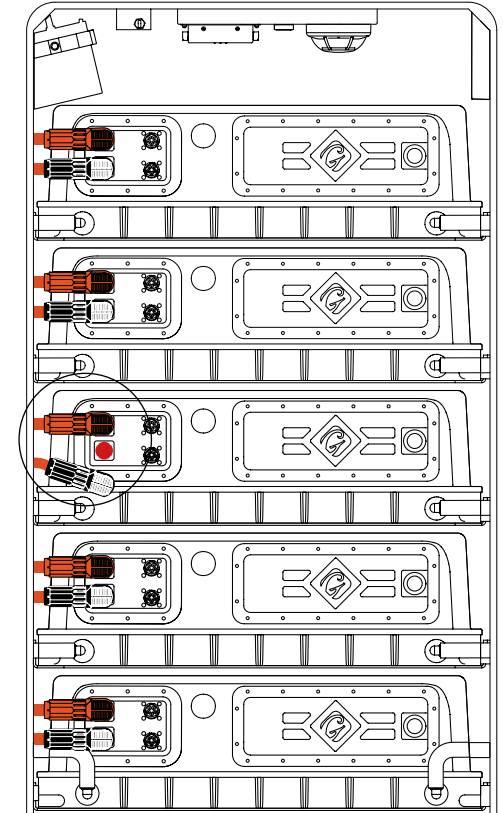
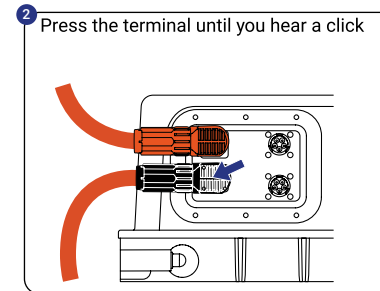
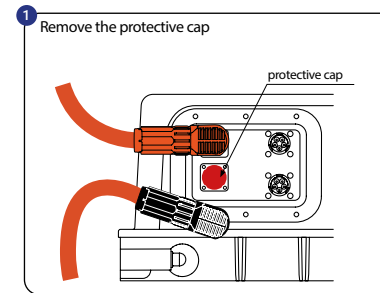

5.2 AC side power-on process

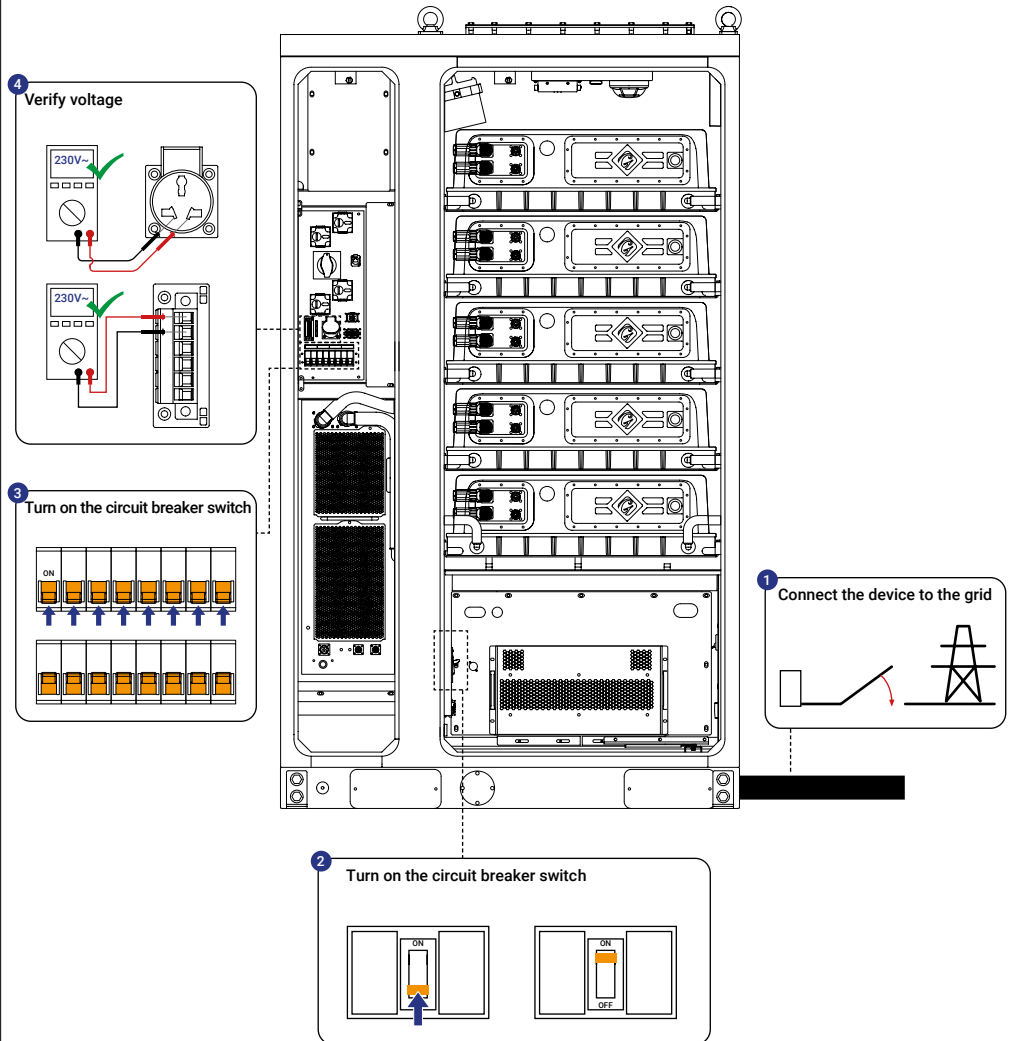

Gotion BESS Ltd.